

Protecting Our Kids from Disasters:

Nonstructural Mitigation for Childcare Centres

No one knows when or where the next winter storm or earthquake will strike. But strike it will, and sooner rather than later. In fact, during the past ten years, natural disasters have occurred more frequently than ever before, putting homes and the lives they shelter in the gravest danger.

This means licensed childcare centres must take serious precautions if they're going to be ready the next time nature lets loose.

That's why the Institute for Catastrophic Loss Reduction, whose mission is to protect families, homes and businesses from snowstorms, wildfires, floods, hailstorms and earthquakes, is pleased to provide you with the Protecting Our Kids from Disasters information kit. The Protecting Our Kids from Disasters program was first developed by the Institute for Business and Home Safety in the United States, where it has been used to make over 1400 childcare centres safer from natural disasters. ICLR has adapted this program to fit our Canadian context, and now you can use it to retrofit your child's childcare centre and others, better preparing them to withstand natural disasters and improving day-to-day safety.

The Protecting Our Kids from Disasters information kit supplies everything your volunteer team will need to perform a basic, nonstructural retrofit from start to finish, including:

- A step-by-step checklist for project leaders;
- Media strategy, including sample news releases;
- An information video that shows examples of possible retrofits in childcare centres, and how to do them;
- Text that puts the how-to information into handy, easy-to-use instructions.

Once upon a time, we could only do so much to prepare for natural disasters. Now we can do much more for only a small investment. After all, British Columbia doesn't get every earthquake. Tornadoes do hit the Maritimes. Wildfires can burn anywhere. And the next hurricane already has a name.

For more information, contact the Protecting Our Kids from Disasters Coordinator at (416) 362-6112 x 352.

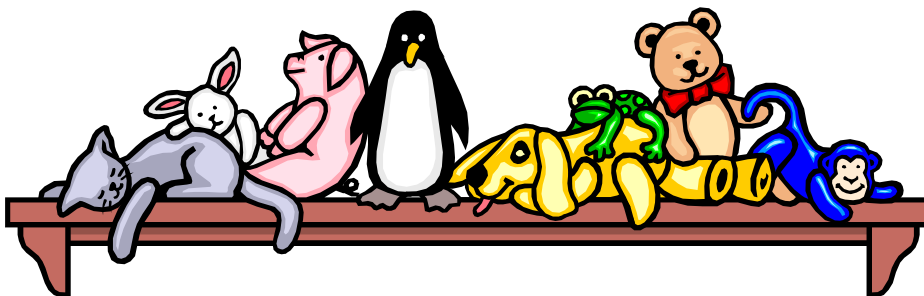

Project Leader's Checklist

Congratulations! You're about to lead a team of volunteers through a Protecting Our Kids from Disasters program designed to non-structurally retrofit your local childcare centre against some of the injuries and damages caused by natural disasters. However, before you jump in and start securing cabinets and installing transparent sleeves over fluorescent lights, you should complete the tasks on this checklist. Then you'll be sure to lead an effective retrofit resulting in a safer childcare centre.

Getting Ready

- ❑ Talk to ICLR or local emergency management officials to figure out which natural disasters happen where you live. Ask them what nonstructural retrofit techniques make sense for protecting against that danger. (See Tab 10)
- ❑ Meet with the owner or operator of your chosen childcare centre(s) and discuss:
 - The nature of the Protecting Our Kids from Disasters program.
 - Which retrofits they may need, and why.
 - What benefits all of you can get in terms of safety and peace of mind.
 - How to cover the cost of materials and supplies.
- ❑ If the centre wants to participate in Protecting Our Kids from Disasters:
 - Inspect the centre to find out exactly what has to be done – the Nonstructural Safety Checklist in the kit will help you determine the types of retrofits needed. In order to better organize the quantity and types of materials required for the retrofit, we recommend that you complete a “walk-through” checklist, with blank columns dedicated to such items as location, quantity, size, material type, and needed tools. In addition, if the childcare centre's owner has no objection, take photos of each room as a reminder.
 - Set up a date to do the work – it usually takes less than a day for 10 to 15 volunteers.
- ❑ Plan the day, the sequence and process required to accomplish the various aspects of the work.
- ❑ Check with local building officials to determine if permits are necessary for the work.
- ❑ Round up your volunteers from among other parents or throughout the community.
 - You might like to join forces with local companies and organizations. For example, insurance companies or banks could be eager to promote Protecting Our Kids from Disasters as a community project; hardware stores could also donate necessary building supplies.



- ❑ Gather necessary tools and materials.
- ❑ Publicize. Protecting Our Kids from Disasters is a great story, and this kit includes tips on media strategies to help you get the word out.

Okay. Now, your troops can install those fluorescent light sleeves and secure those cabinets.

After the Retrofit

- ❑ This kit holds tip sheets about protecting homes from natural disasters. Leave copies of these behind when you've finished, so the centre can give them to all parents.
- ❑ Tell the ICLR Coordinator that the retrofit is complete.
- ❑ Fill out the Project Wrap-up Form you'll find here in the kit, and mail it off to ICLR.
- ❑ Give your team a pat on the back, and give yourself one, too!



Publicizing Your Event

Imagine this scenario. Natural catastrophe heads our way. Our children spend their days in possible peril. You and your volunteers show how to help protect the kids. This is a great story and you might get your local newspapers and radio and television stations to cover it. Here's how.

1. Always have fun, be inventive and be enthusiastic. Reporters and their editors like excitement. Protecting Our Kids from Disasters has plenty.
2. Get a list of addresses, fax and phone numbers for all the newspapers, radio and television stations that cover you community. Ask around to find out if anyone knows a reporter or an editor at any of the papers or stations. These are the best media connections and they are always looking for good stories.
3. Appoint a team member as media contact. Chose somebody who is full of fun, invention, enthusiasm and persistence.
4. Write a media advisory that persuades news people not only to attend your retrofit project but also to interview you and your media contact beforehand.
5. Fax the advisory to city editors at newspapers and assignment desks at television and radio stations five days before the event. Have your media contact call your connections at the papers and stations to put in a good word.
6. On the day before the event, have your media contact call the editors to be sure they have assigned reporters to cover the retrofit. Remember, these editors are busy and working on deadlines so they don't have much time for chat. On the other hand, they need stories. Your media contact can sell them your story.
7. Your media contact should be a high-energy person. If you talk to the media, you should be that sort of person too. Give your interviews in visual, action-packed terms. You're protecting children from disasters and there's no time for reticence.
8. On the morning of the event, have your media contact fax out the advisory again along with a full news release on the project.
9. During the retrofit, the media contact should be on hand to talk about the project to reporters and to bring over individual volunteers for interviews.
10. Don't neglect your small community papers and weeklies. Sometimes the best stories take hold first at the grass roots level.



Sample Media Advisory

(Printed on Your Childcare Centre/ Organization Letterhead)

Children at (*childcare centre*) on (*street*) in (*your town*) are in potential danger. Even as you read this, open water currents, trade winds, air and water temperatures meet in the Caribbean for the annual ritual that spawns hurricanes. These forces could jeopardize our children's safety.

The parents of (*childcare centre*)'s charges are determined, however, that the first hurricane to reach (*your town*) will find the centre prepared to withstand its wrath. These volunteers know what they must do to keep their children safer, and they plan to do it this Saturday from 8 a.m. to 2 p.m. on-site at the (*childcare centre*).

For more information on the peril and its timely remedy, or to interview one or more volunteers, contact Ceil Havey immediately at xxx-xxxx (day) and xxx-xxxx (night).



Change this sample to fit the natural disasters to which your region is prone. Come up with your own more inventive, more local angle to get attention and stimulate interest.

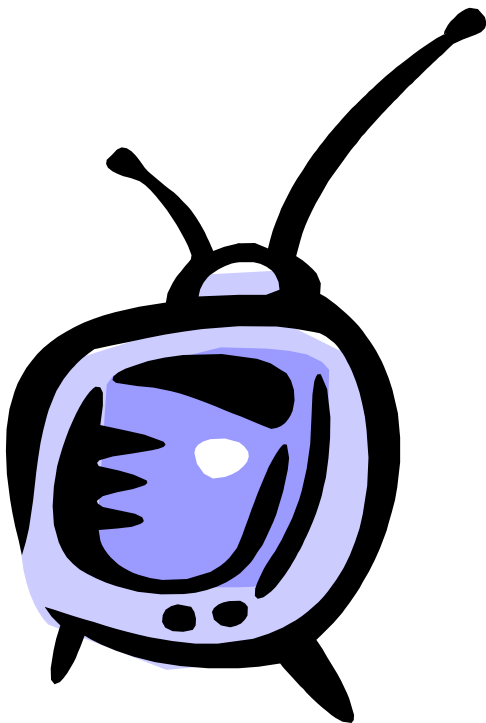

Sample News Release

(Printed on Your Childcare Centre/Organization Letterhead)

FOR IMMEDIATE RELEASE

Contact: Ceil Havey

Day: xxx-xxxx

Night: xxx-xxxx

PARENTS TAKE EXTRA STEPS TO PROTECT KIDS FROM NATURAL DISASTERS

(*YOUR TOWN, Today's Date*) – This morning, the children of the (*childcare centre*) began the day as they have begun every day – blissfully unaware that they might be in danger. By evening, the children were safer.

A day's worth of work by fifteen parents, friends and neighbours eliminated several situations that posed the risk of harm to (*childcare centre*)'s 45 enrolled children. Working in concert with the Protecting Our Kids from Disasters program, these volunteers gave the centre a basic, nonstructural fix-up that improves its ability to protect children when a natural catastrophe strikes and allows it to keep its doors open for business afterwards.

Protecting Our Kids from Disasters is a national preparedness program of the insurance industry to reduce the human and financial impact of earthquakes, flood, hurricanes, tornadoes and wildfires.

Thomas Tiddlywink, who organized the volunteer effort, said helping retrofit the (*childcare centre*) is his responsibility as a dad. "My daughter spends five days a week at this center. The staff is good at what they do, but it's still up to me to make certain my child is safe. We took simple and affordable precautions here today that will give me and every other parent peace of mind that our kids are cared for in a safer environment."

Tiddlywink and his team's work involved simple but crucial attention to nonstructural situations that, while often overlooked, have the potential to do real damage. Bookshelves that could tip over, the team bolted to the wall. Where objects could fall from shelves, the team installed ledge barriers. The team secured a massive cabinet to a wall and added door latches to it. They secured pictures and bulletin boards and reinforced light fixtures. They added support to a false ceiling and added shatter-proofing film to window glass. They secured two water heaters and trimmed several overhanging trees. They cleared fire-prone vegetation and cleaned roofs and gutters of accumulated leaves. They also checked fire extinguishers and smoke detectors and put together an emergency disaster kit that included a three-day supply of food and water, first aid supplies, blankets, flashlights and a AM/FM radio. Last, but not least, they provided information that all parents whose children attend the centre can use to protect their homes.



Protecting Our Kids from Disasters

As the volunteers went into action, (*childcare centre*) Director Sarah Childcare expressed her appreciation. “I’m thrilled that parents have stepped forward to help us make the centre more secure during natural emergencies. When the next big storm hits, we’ll be ready, and now it’s far more likely that the children will have a place to come back to when everything is over.”



Change this sample to fit the natural disasters your region is prone to. Come up with your own more inventive, more local angle to get attention and stimulate interest.



Project Wrap-Up Form

Once you have secured the last bookshelf and your retrofit job is done, please let us know what you think of the Protecting Our Kids from Disasters program. If you, and the other team leaders, fill out this form, we at ICLR can put your feedback to use in protecting kids that much more effectively.

Make as many copies as you need and, when they're complete, mail them back to:

**Protecting Our Kids from Disasters Coordinator
Institute for Catastrophic Loss Reduction
151 Yonge St., 18th Floor
Toronto, ON
M5C 2W7**

Phone: (416) 362-6112 ext. 352

Fax: (416) 361-5952

E-mail: twaddington@iclr.org



Protecting Our Kids from Disasters

Project Wrap-Up Form

Childcare Centre Information: Name: _____

Address: _____

Phone: _____

Contact: _____

Volunteer Organization(s): Name: _____

Team Leader: Name: _____

Organization: _____

Phone: _____

My child attends this centre: _____

Date of Retrofit: _____

How many volunteers participated in the retrofit? _____

How long did the retrofit take to complete? _____

Were materials donated? If so, by who? _____

[If you have one, attach a list of items completed in the retrofit.]

Evaluation of Retrofit Kit:

Rate the kit for effectiveness on a scale of 1 (Terrible) to 5 (Excellent).

1. Project Leader's Checklist	1	2	3	4	5
2. Nonstructural Safety Checklist	1	2	3	4	5
3. Publicizing Your Event	1	2	3	4	5
4. Retrofit Instructions	1	2	3	4	5
5. Leave-Behind Materials	1	2	3	4	5

Please write any other comments you have on the back of this sheet.

Return to:

Protecting Our Kids from Disaster Coordinator
Institute for Catastrophic Loss Reduction
151 Yonge St., 18th Floor
Toronto, ON M5C 2W7



Protecting Our Kids from Disasters

Retrofit Instructions

Childcare facilities typically have the same nonstructural hazards as other kinds of buildings. However, these hazards should be eliminated because young children are especially vulnerable. Even a small shelf falling on a young child can do serious harm.

This section of Protecting Our Kids from Disasters offers detailed instructions for dealing with nonstructural hazards. The instructions here, and in the accompanying video cover these specific areas:

- **Bookcases**
- **Cabinets and Drawers**
- **Large Appliances and Vending Machines**
- **Picture Frames and Bulletin Boards**
- **Ceiling Lights, Suspended Ceilings and Hanging Fixtures**
- **Windows and Doors**
- **Water Heaters, Pipes and Ducts**
- **Landscaping**

The repairs specified in this section are based on common sense. If you notice anything that needs attention, by all means add it to your list of tasks.

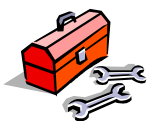
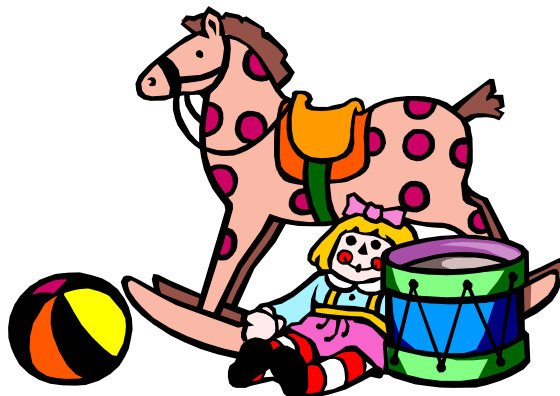

Bookcases

Perfect for storing books, toys and supplies, bookcases are an indispensable feature in any childcare centre. Bookcases can shake and tip causing their contents, and sometimes the shelves themselves, to fall to the floor.

Fasten all bookcases securely to a wall.

One way to do this is by attaching either L-brackets or Z-brackets between the bookcases and the wall after pre-drilling holes in each. Be sure to use a bracket that can accommodate the fasteners you are using. See Figure 1 for details.

- Attaching the bracket to the bookcase:
 - For wood bookcases, attach the bracket with #8 (or larger) wood screws. The screw should be long enough to secure the bracket to the shelf without punching through and creating a sharp edge.
 - For plastic and metal shelves, use #8 (or larger) machine screws with washers and nuts to ensure that the bracket will stay in place. The screw should be long enough to accommodate the bracket, shelf, washer and nut.
- Attaching the bracket to the walls:
 - For wood stud walls, use 7.5 cm (3") long #8 (or larger) wood screws to attach each bracket to the wall. Place screws in the wood studs to assure that they are properly supported. Use a stud locator to find the best places.
 - For stone or masonry walls, place plastic anchors in the holes before you screw in 7.5 cm (3") long #8 (or larger) screw, or consider using 0.5 cm (3/16") diameter (or larger) masonry screws.

Figure 1: Attachment Methods for Bookcases

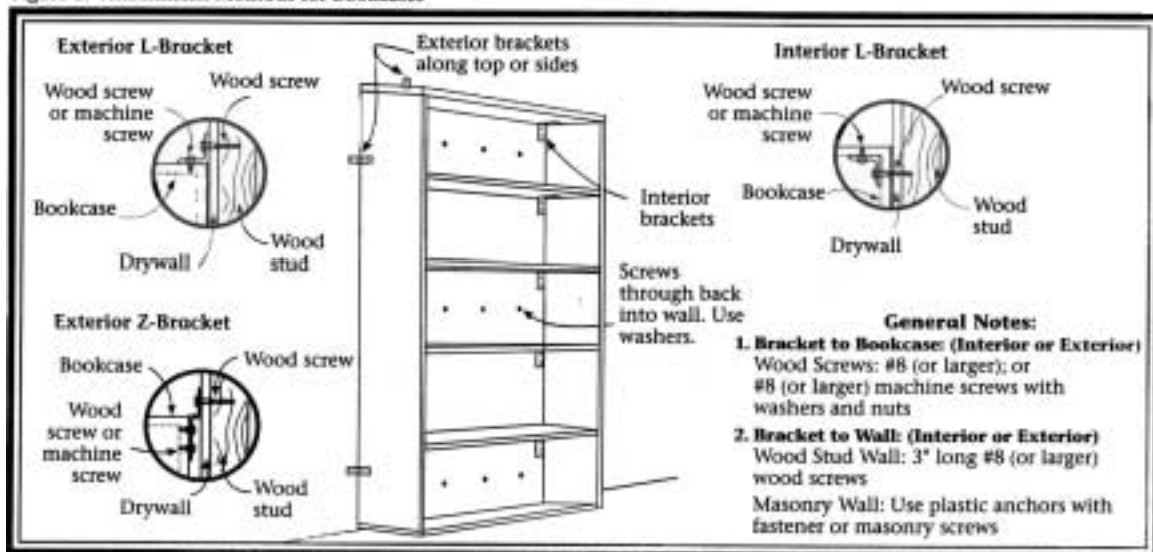
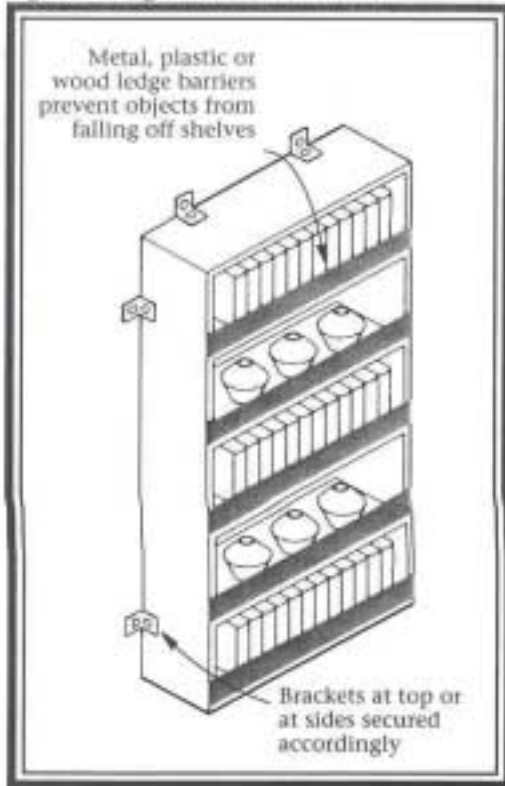

Figure 2: Ledge Barriers for Bookcases



For a bookcase with a solid back, pass screws directly through the back into the wall. Use washers to spread contact over a larger area between the screw and the bookcase's back. If you are working with a wood stud wall, use a stud locator to find the best locations for the 7.5 cm (3") long #8 (or larger) wood screws. For a stone or masonry wall, use plastic anchors with the #8 (or larger) screws, or use 0.5 cm (3/16") diameter masonry screw.

Prevent items on shelves from falling by installing ledge barriers made from strips of wood, metal or plastic. Cut them to fit the shelf and attach them with glue or mechanical fasteners. Finish the barriers to match the shelves. See Figure 2 for details.

Place heavy items on lower shelves.

Stabilize bookcases that are not against walls by attaching them back-to-back with #8 (or larger) machine screws, oversize washers and nuts. See Figure 3.

Figure 3: Attach Freestanding Bookcases Back-to-Back

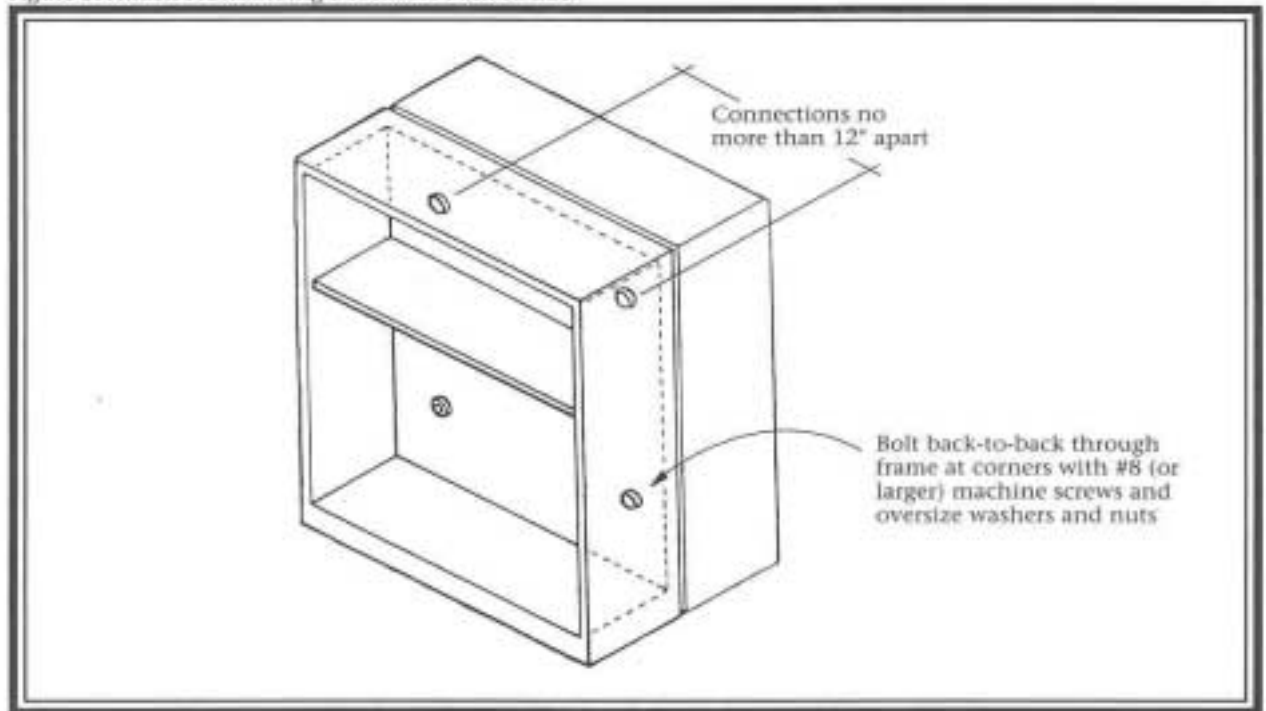
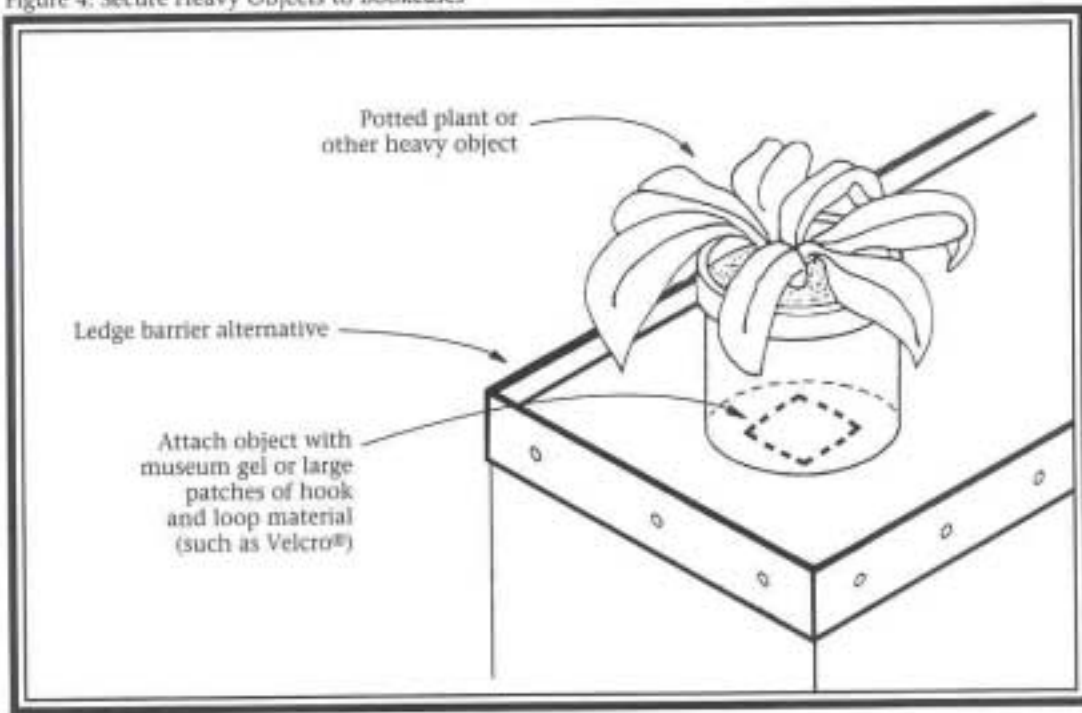

Figure 4: Secure Heavy Objects to Bookcases



- Affix large, heavy items, such as plants and aquariums, and breakables directly to the shelf to keep them from falling. Apply hook and loop material (such as Velcro®) or museum gel to secure these items. For added protection use metal, plastic or wood ledge barriers. See Figure 4 for details.

Necessary Tools and Materials

- L- or Z-brackets _____(quantity)
- Fasteners _____
- Plastic anchors for masonry walls _____
- Variable speed drill and bits _____
- Screwdriver _____
- Stud locator _____
- Wood, plastic or metal strips _____
- Paint or wood finish _____
- Hook and loop material, or museum gel _____



Cabinets and Drawers

Cabinets can tip over just like bookcases, and their sharp-edged drawers can slide out with dangerous consequences. Moreover, the cabinet door and drawers may open, spilling their contents.

- To secure them, do the following:
 - Attach cabinets to the wall and floors using L-brackets or Z-brackets. Again, be sure to use brackets that can accommodate the diameter of the fasteners. You should follow the specific directions give in Figure 5 below and in the “Bookcases” section for securing the bracket to the wall and cabinet.
 - Secure freestanding cabinets to the floor with a metal angle so that, during an earthquake, they will not move or tip over. Use an angle that can accommodate the diameter of the fasteners. The fasteners should be long enough to accommodate the thickness of the angle and be adequately embedded in the floor, floor joists or concrete slab.

Figure 5: Secure Cabinets and Drawers

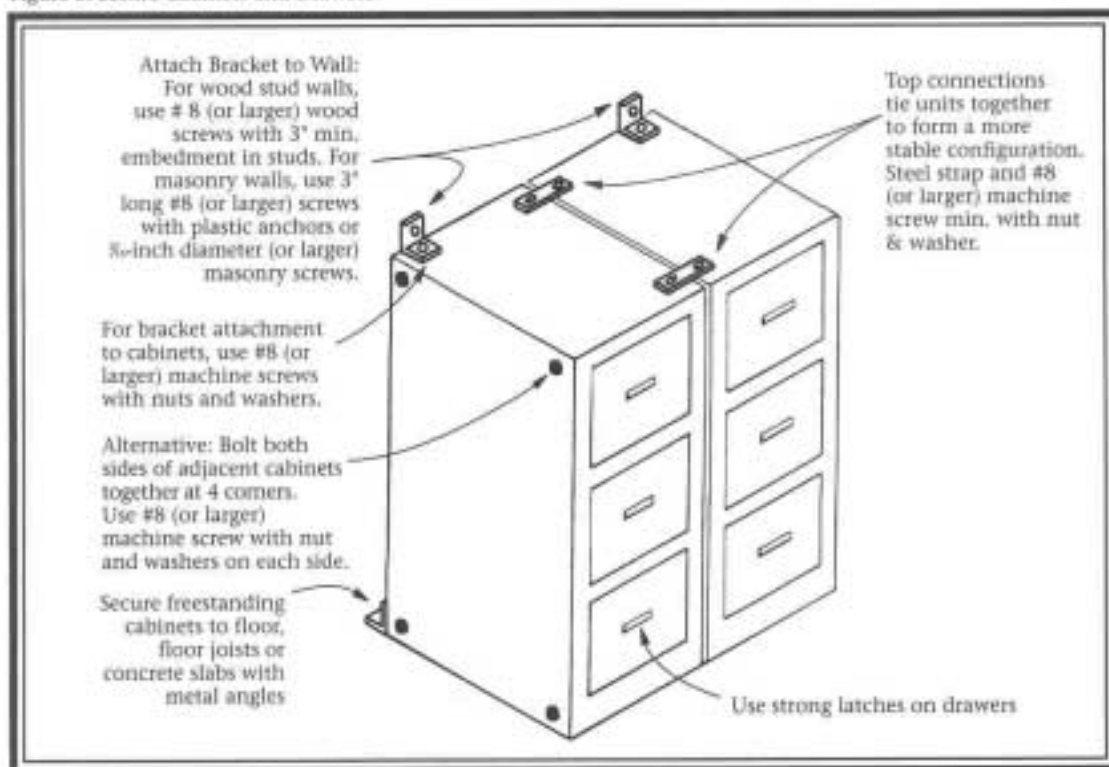

- If several cabinets stand side-by-side, you can fasten them together to form a wider footprint using #8 (or larger) machine screws.
- Attach simple mechanical or self-locking latches to cabinet drawers so they cannot slide open.



To prevent cabinet doors from swinging open and spilling their contents, install mechanical or self-locking latches. A variety of types are available at your local hardware store. See Figures 6&7 for details.

Figure 6: Secure Cabinet Doors and Drawers

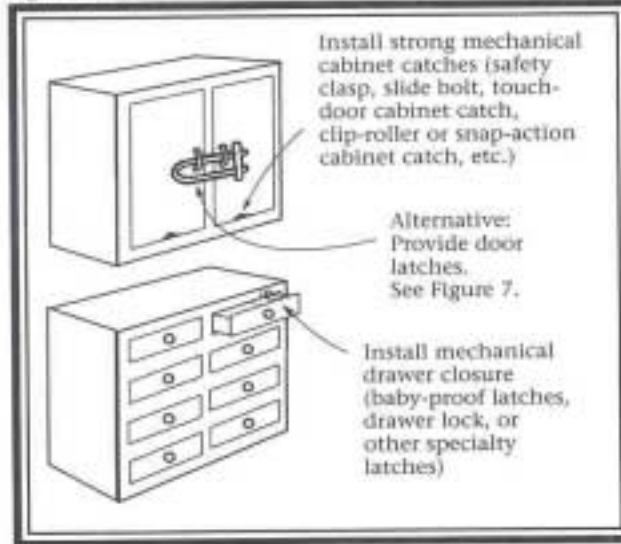
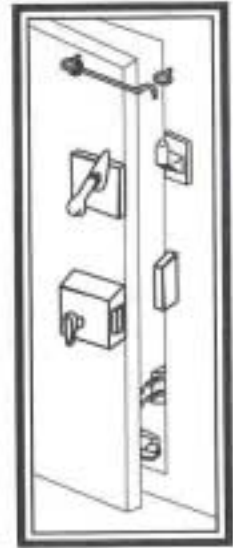
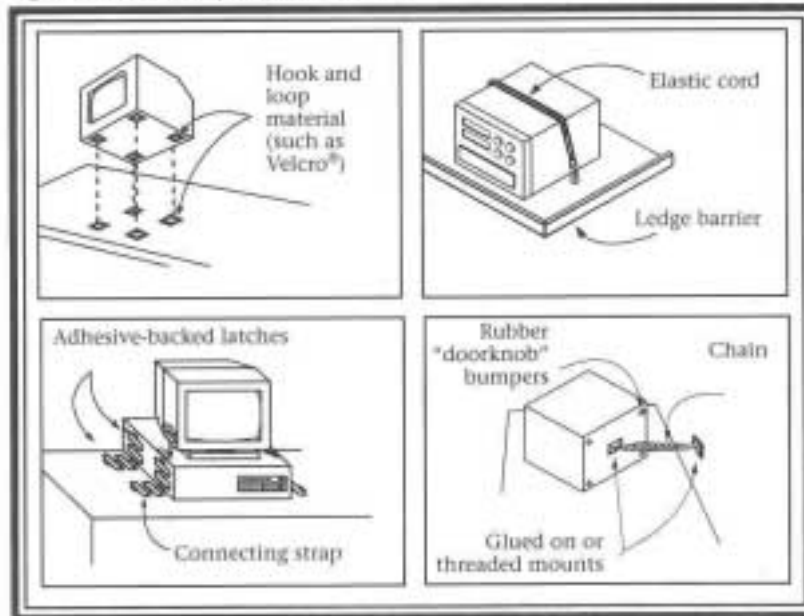

Figure 7: Close-up of Door Latches



- Heavy objects such as televisions, computers and stereos are usually placed on top of cabinets, bookcases, and tables. Fasten these items so they will not slide off during an earthquake or hurricane. Several methods of attachment are shown in Figure 8.

Figure 8: Secure Heavy Objects to Shelves



Necessary Tools and Materials

- L- or Z-brackets _____
- Fasteners _____
- Door or drawer Latches _____
- Plastic anchors for masonry walls _____
- Variable speed drill and bits _____
- Screwdriver _____
- Stud locator _____



Large Appliances and Vending Machines

Large appliances and vending machines can slide or fall over from the force of an earthquake or windstorm. Furthermore, heavy objects on wheels can roll if brakes are not provided and locked.

- Anchor large appliances and vending machines to walls using safety cables or straps. The restraint should be located in the mid- to upper-portion of the appliance. Be sure to choose screw-eyes that are sized appropriately for the appliance. Use one of the following methods:

Method 1:

- For wood stud walls, use a stud locator to find the best wall location to install screw-eyes.
- Connect coated wire cable to the screw-eye at one end and to a snap-hook fastener at the other end.
- Attach the safety cable to the appliance with the snap-hook fastener.

Method 2:

- For wood stud walls, use a stud locator to find the best wall location to install two screw-eyes on either side of the appliance. For stone or masonry walls, place plastic anchors in the predrilled holes before you install the screw-eyes.
 - Wrap the coated wire cable around the appliance, connecting it with snap-hook fasteners to the two screw-eyes secured into the wall.
- Replace rigid water or gas connections on large appliances with listed or approved flexible connectors.
 - Check local building codes to see if flexible connectors must be installed by a professional.
 - Always lock the rollers of any large appliances or pieces of furniture (e.g., pianos).

Necessary Tools and Materials



- Coated wire cable or other strapping system _____
- Variable speed drill and bits _____
- Screwdriver _____
- Screw-eyes _____
- Hook fasteners _____
- Flexible connectors _____
- Stud locator _____
- Plastic anchors _____



Picture Frames and Bulletin Boards

Pictures and bulletin boards play essential roles in the spirit and function of a childcare centre, but both will fall during a violent storm or earthquake if they are not securely fastened to the wall.

There are two ways to prevent them from falling.

1. Use closed eye screws, instead of traditional picture hangers, for securing picture frames, bulletin boards and mirrors.
 - Depending on the weight of the object and the screw-eye's maximum weight limit, screw one or more closed screw-eyes into wall stud(s). Use a stud finder to determine the appropriate location for the screw(s).
 - Attach picture wire to one side of the frame. Then thread the wire through the closed screw-eye, fastening it securely to the other side of the frame. See figure 9.

Figure 9: Secure Picture Frames to Wall

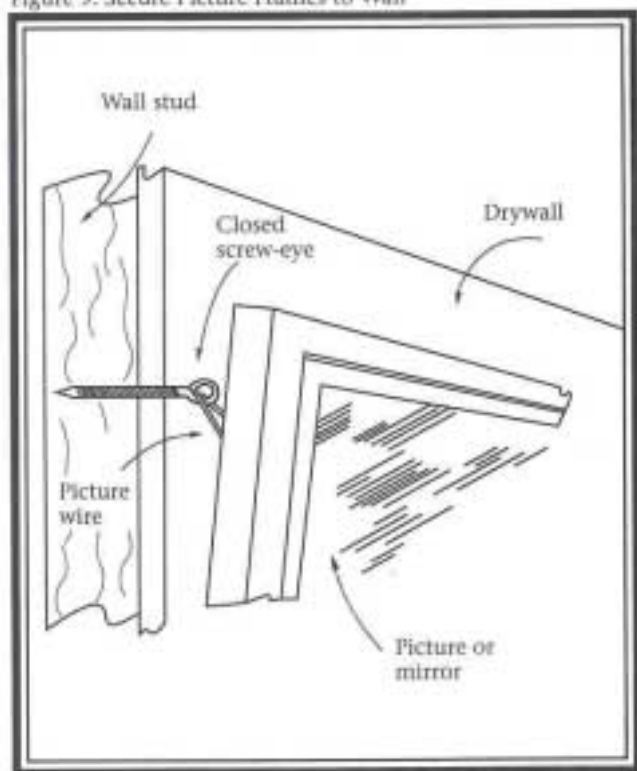

2. An alternate plan involves using an open picture hanger. Hook and loop material (i.e. Velcro®) can be attached to the bottom corners of the frame and anchored to the wall.
 - Always mount heavy or sharp wall hangings away from places where they could fall on children.

Necessary Tools and Materials

- Stud locator _____
- Screwdriver _____
- Variable speed drill and bits _____
- Screw-eye(s) _____
- Heavy Picture wire _____
- Pliers _____
- Hook and loop _____

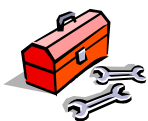

Ceiling Lights, Suspended Ceilings and Hanging Fixtures

If not well attached and supported, ceiling lights, suspended ceiling, and hanging fixtures can fall down in a natural disaster with serious consequences for the children below.

- Secure ceiling lights to supports using safety cables.
 - Use a chain strap or a minimum 14 gauge wire to attach each of the light fixture's four corners to a nearby ceiling support. Locate the support visually or use a stud locator. Be sure to leave the safety cables slack; they should not support the weight of the lights under normal circumstances. See figure 10 for details.
 - If the ceiling light has a cover, keep it from falling during an earthquake or windstorm by fastening it to the fixture itself or to the permanent structure.
 - Pay special attention to the fluorescent lights. Installing plastic sleeves over the fluorescent light tubes will keep the glass from shattering if they break. As an alternative, consider using Teflon fluorescent lights, which are shatter resistant.

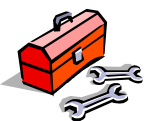

Figure 10: Secure Ceiling Lights to Supports with Safety Cables

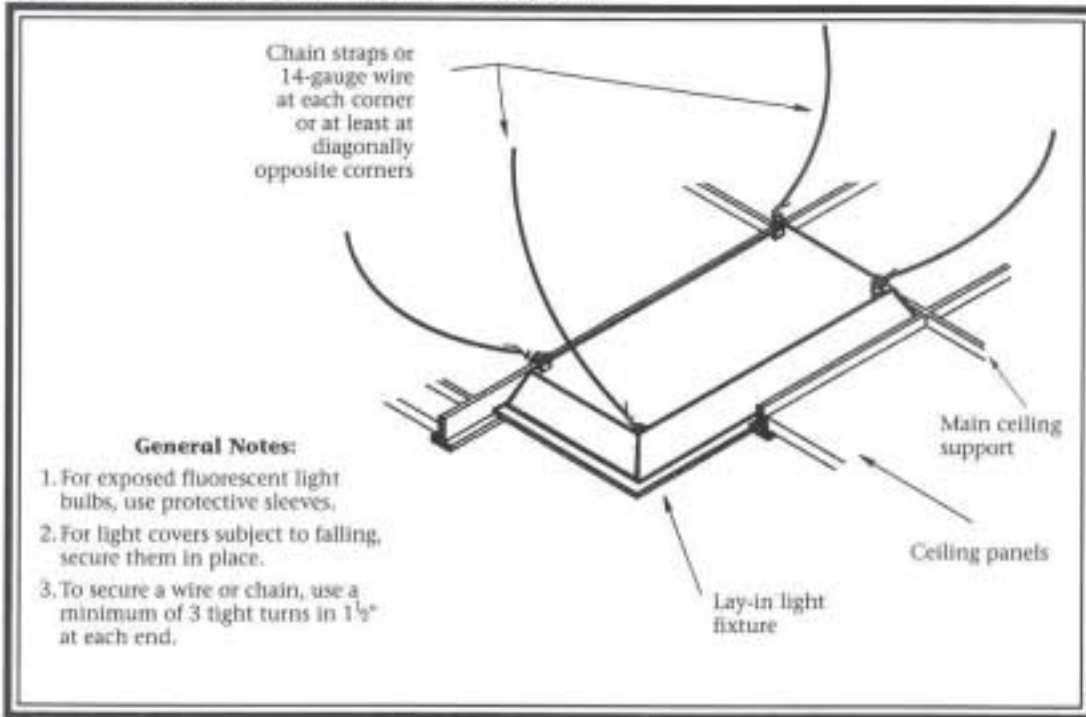
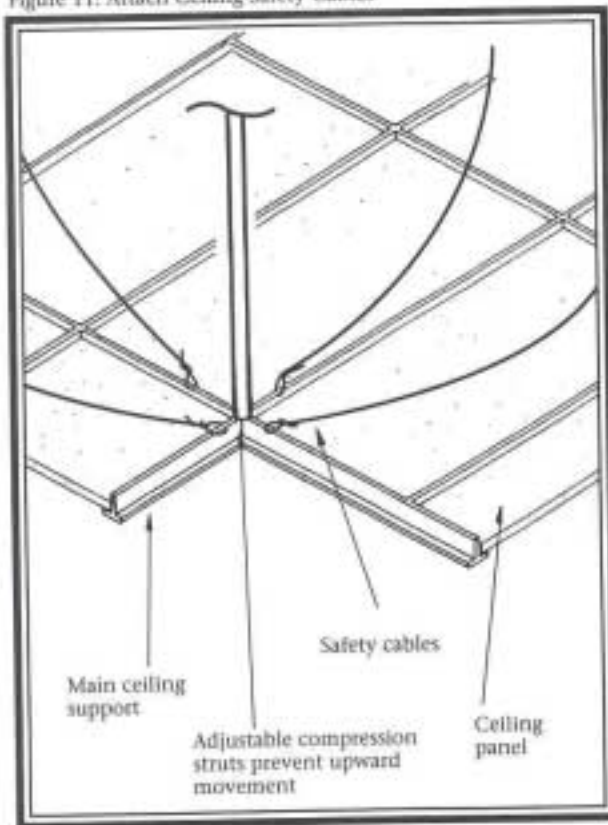
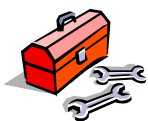

Figure 11: Attach Ceiling Safety Cables



- Using safety cables, attach suspended or false ceilings to permanent structural members every few feet.
 - Use chain straps, plumbers strapping or heavy wire (minimum 14 gauge) to secure suspended or false ceilings. See figure 11.
 - Screws, bolts or other appropriate fasteners should be used to attach the safety cables to both the suspended ceiling and the permanent structural members.
 - In order to prevent upward movements, adjustable compression struts can be installed.



- Make sure ceiling fans, plants and other suspended fixtures are safely secured to permanent structural members.
 - All items suspended from the ceiling need a safety cable to connect the fixture to a strong support. The safety cable should not support the weight of the item under normal circumstances. Instead it should remain slack.
 - Keep in mind that hanging items may sway easily. Make sure these objects will not collide with anything if they should begin to swing.

Necessary Tools and Materials

- Safety cables, chain straps, heavy wire _____
or plumbers strapping
- Fasteners _____
- Screwdriver _____
- Plastic sleeves for fluorescent lights _____
- Light covers _____
- Stud Locator _____
- Variable speed drill and bits _____

Windows and Doors

Windows and glass doors do much to brighten up life in any childcare centre, but in a natural disaster glass can break, sometimes explosively. This puts children in danger, not only from the flying glass, but also from exposure to the violence of the elements outside the building.

- Childcare centres have either double or single entry doors. If they are solid wood or hollow metal, they probably can resist wind pressures and wind-borne debris. Nonetheless, the following precautions should be taken to ensure that the doors do not fly open during a disaster and expose the centre to additional damage.

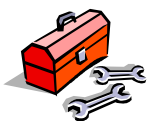
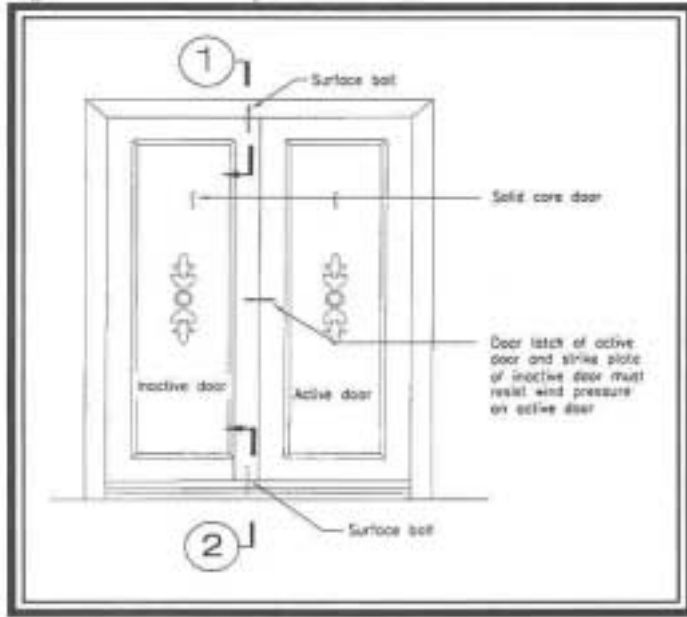

Figure 12: Double Entry Door Elevation



- Install head and foot bolts on the inactive door of double entry doors.
- Make sure the doors have at least three hinges and a dead bolt security lock that has a minimum 2.5 cm (1”) bolt throw length.
- Since double entry doors fail when their surface bolts break at the header trim or threshold, check the connections at both places. Be sure the surface bolt extends into the door header and through the threshold into the sub-floor. See figure 12 for information.

Figure 12a: Header Detail

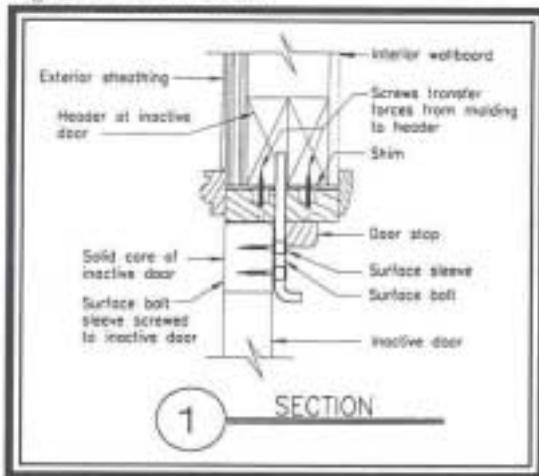
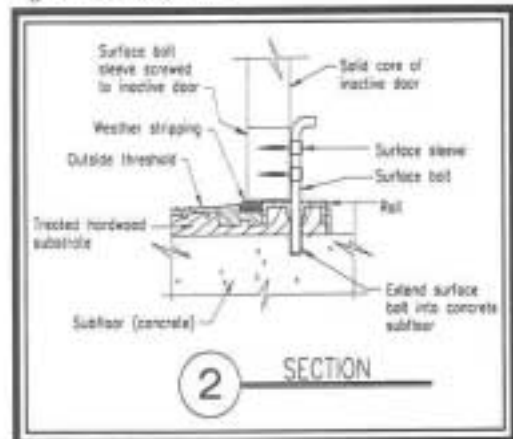
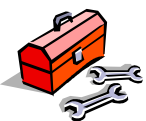

Figure 12b: Footer Detail



- Apply a protective safety film to windows and glass doors to make them safer.
 - A protective film (minimum thickness of 4 mm) can be used on all types of glass, including tempered glass and annealed glass. It comes in rolls and is available at local hardware and home improvement stores. Install the film according to the manufacturer’s instructions. The installation process usually includes the following steps.
 1. Precut the film to a size slightly larger than the windowpane to which it will be applied.
 2. Clean the glass.



3. Moisten the glass with water from a spray bottle.
4. Peel off the removable backing and apply the film to the glass.
5. Use soapy water and a squeegee to smooth the film and remove air bubbles.
6. Cut away any excess film with a utility knife. Be careful not to score the glass.

➤ As an alternative, consider professional installation.

Necessary Tools and Materials

Safety film	___	Plywood	___
Spray bottle with clean water	___	Saw	___
Squeegee	___	Heavy-duty fasteners	___
Soapy water	___	Measuring tape	___
Utility knife	___	Stud locator	___

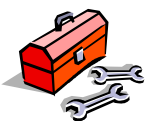

Water Heaters, Pipes and Ducts



Even if children do not have immediate access to them, water heaters can tip over and spill dangerously hot water into a building. If the heater is run on flammable gas and the gas line breaks, the situation becomes far more serious. Similar problems afflict overhead pipes and ducts.

- Secure water heaters (up to 50 gallons or 190 L) to stud walls using the simple, generic method detailed in Figures 15-17.
 - You can anchor the water heater using items that are readily available from the local hardware store, including:
 - Heavy-duty shelving brackets;
 - 2 cm (3/4") plumber's strapping (metal strapping with perforated holes);
 - 2x4 wood blocking; and
 - Various fasteners.
 - To begin: fasten two 2x4 wood blocking strips to the nearby wall — one at a height within the upper one-third (1/3) of the water heater and the other within the lower one-third (1/3) of the water heater. The lower 2x4 should be at least 10 cm (4") above the water heater control. If you are working with a wood or metal stud wall, attach the blocking directly to the studs. Use a stud locator to find the studs.
 - Fasten heavy-duty shelving brackets to the wood blocking. These brackets should fit snugly against the water heater.
 - Wrap plumber's strapping around the heater and secure it to the brackets.
- Use flexible connections for all utility connections instead of rigid connectors.
 - Be sure to check with local building code officials to see if a licensed plumber is required to install flexible connections.
 - Try to get a local plumber to volunteer services and become part of your team.
- Make certain everyone on the centre's staff knows where to locate the gas shut-off valve, and how to operate it.
- Secure pipes and ducts to permanent structural members using a combination of angle braces and plumber's strapping or safety cable.

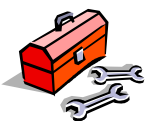

Figure 15: Overview of Typical Retrofitted Water Heater

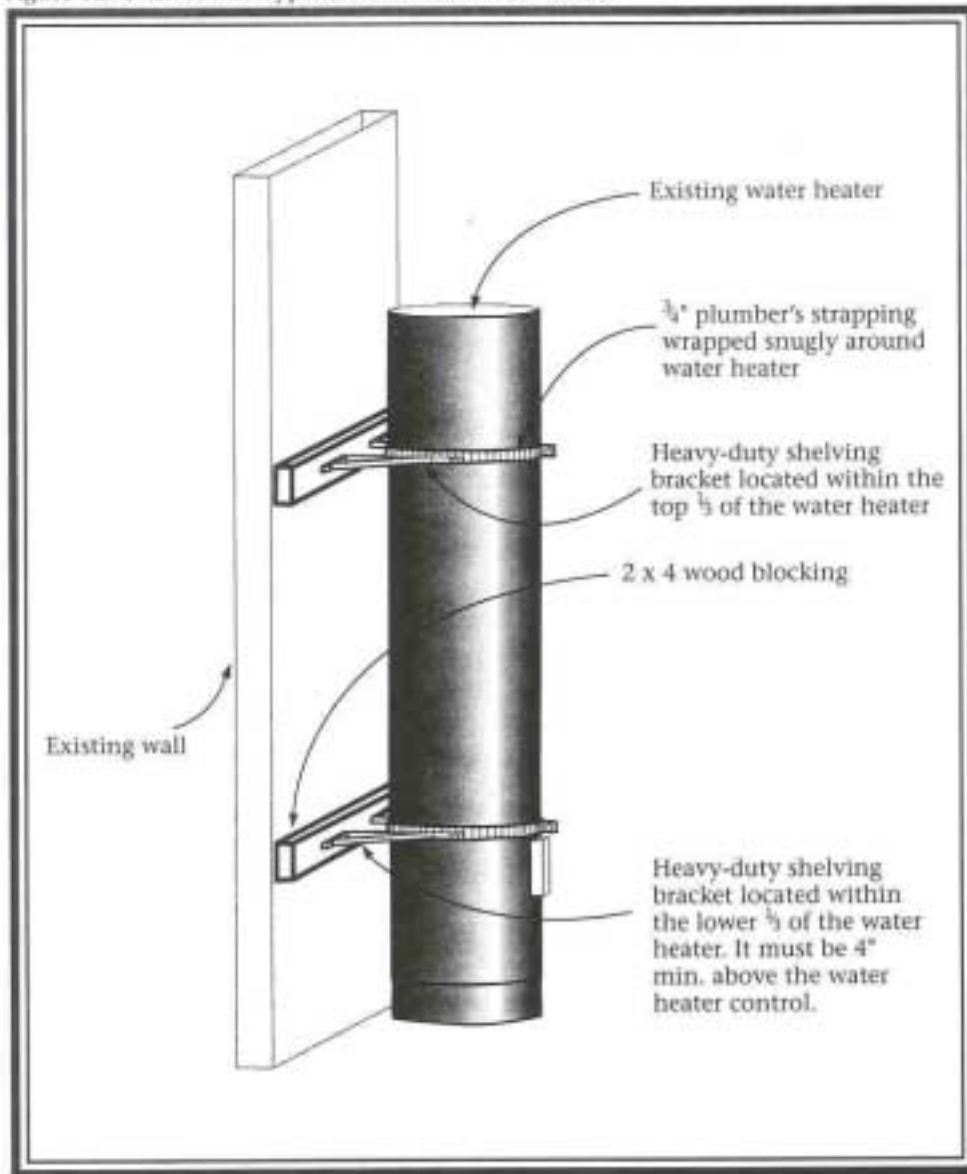

Figure 16: Straight Wall Configuration

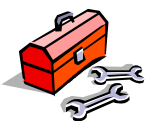
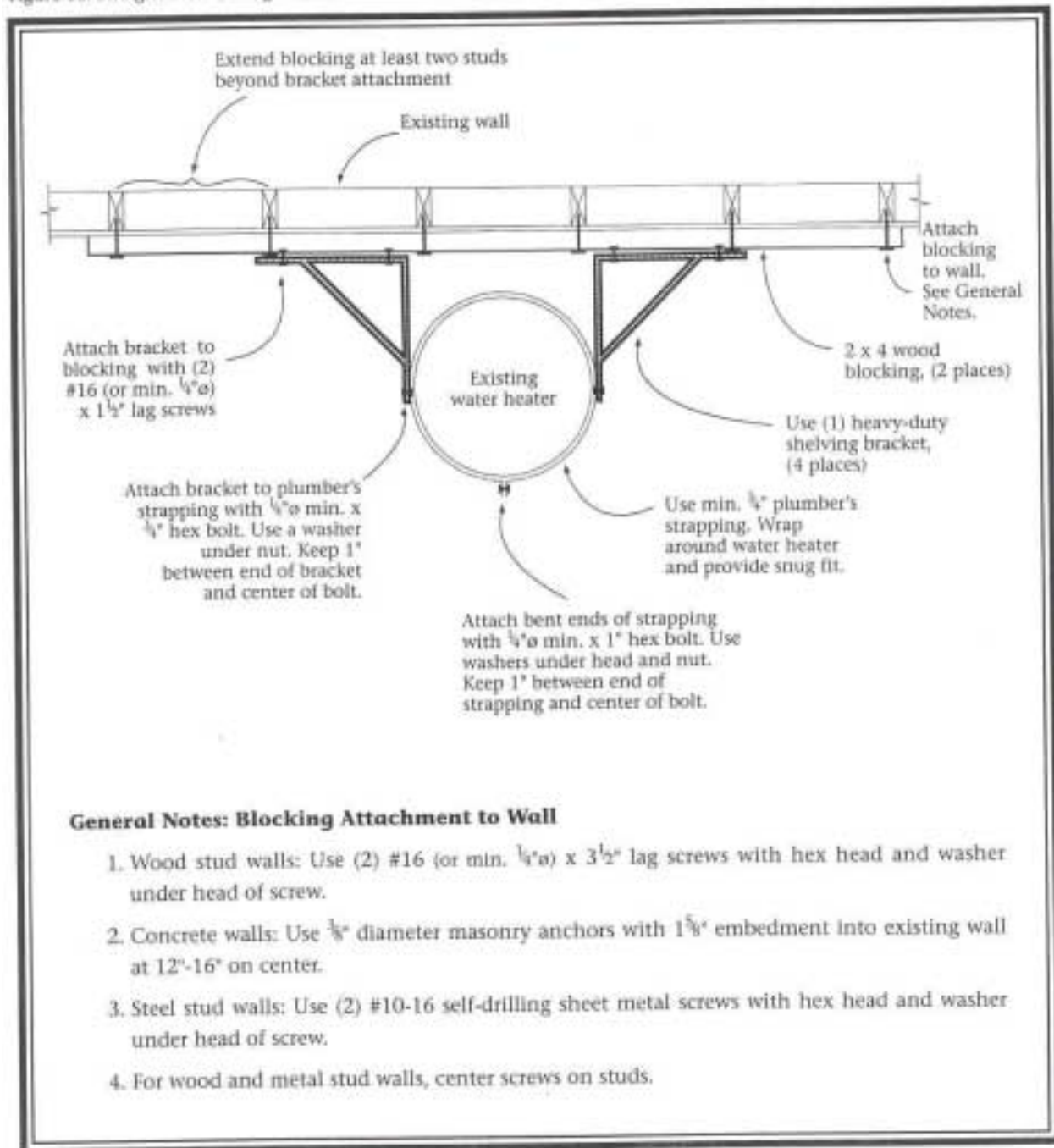
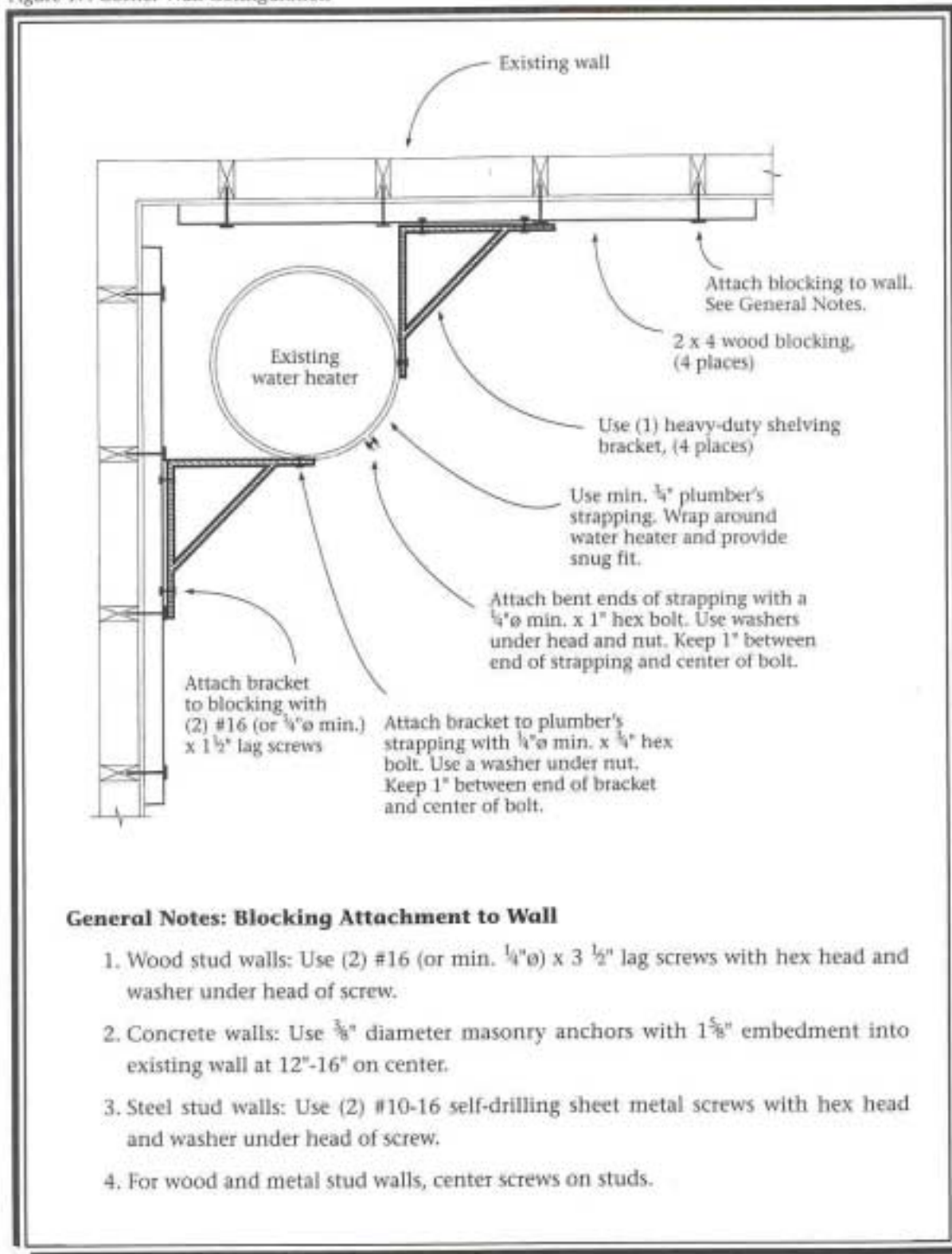
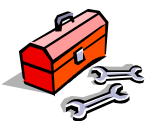

Figure 17: Corner Wall Configuration



Necessary Tools and Materials

- 2x4's _____
- Stud locator _____
- Screwdriver _____
- Variable speed drill and bits _____
- Heavy-duty shelving brackets _____
- Plumber's strapping _____
- Screws _____
- Slotted angles or L-brackets _____
- Flexible connector _____



Landscaping

A yard has to be maintained for safety as well as beauty. Unkempt brush and dry lawns can catch fire; so can sheds and woodpiles. Overhanging tree limbs, and entire diseased trees can fall through a roof.

Figure 18: Landscape Layout

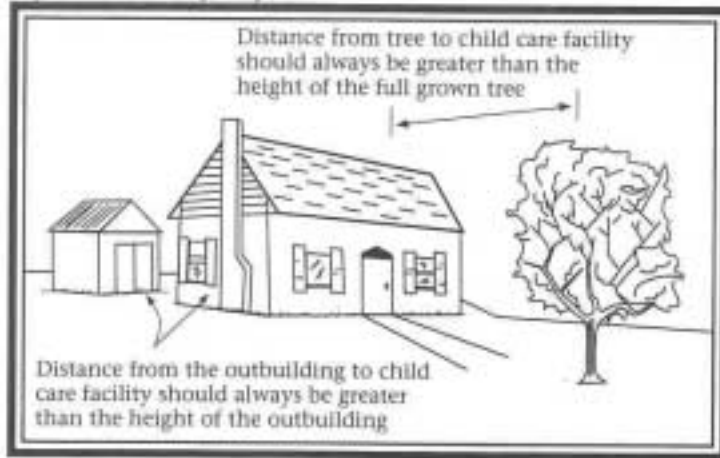

- Make sure that the street number of the centre is clear and legible from the street. This will ensure that emergency vehicles do not have trouble locating the centre.
 - A well-maintained yard is the key to preventing damage from fires and other disasters. See figure 18 for details.
-
- Position trees at least 3 m (10') apart and at least 30.5 m (100') from the childcare centre.
 - Remove any dead trees or trees that pose a threat of falling on the childcare centre.
 - Prune trees up to 1.8 m (6') from the ground and trim branches that extend over the roofs of buildings.
 - Clean pine needles, leaves and other debris from roofs and gutters often.
 - Mow the lawn and remove leaf clutter regularly.
 - Be sure to irrigate the yard periodically.
 - Enclose the undersides of aboveground decks with non-combustible materials, such as wire mesh, in order to prevent the buildup of leaves and other debris.
-
- For landscaping, plant native, fire-resistant vegetation, and avoid vines or climbing plants that may serve as a link between grass and treetops or roofs during a fire.
 - Store firewood 15.25 m (50') away from the building so as not to provide fuel for a fire.

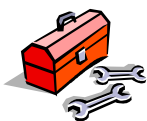

Nonstructural Mitigation for Childcare Centres

Necessary Tools and Materials

- Handsaw _____
- Pruning sheers or loppers _____
- Lawnmower _____
- Irrigation system _____
- Rake _____
- Native, fire-resistant vegetation _____
- Bins for debris _____

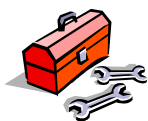

Technical References

“Identification and Reduction of Nonstructural Earthquake Hazards in Schools.”

Federal Emergency Management Agency. July 1993

<http://www.fema.gov/MIT/schfae.htm> 1/ 28/98

Mroz, M.P., and T.T. Song. Fire Hazards and Mitigation Associated with Seismic Damage of Water Heaters. NIST. Gaithersburg, MD 1997

“Reducing Risk Through Mitigation: The Mitigation How-To Series”.

Federal Emergency Management Agency. <http://www.fema.gov/MIT/homemit.htm>

1/ 28/98.

Tate, Morris. Hurricane Survival Made Easy. Wisdom Market Press.
North Miami Beach Florida. 1993.

“Techniques for Mitigating Earthquake Hazards.” *Association for Bay Area*

Governments. 4/1/97. <http://www.abag.ca.gov/bayarea/eqmaps/fixit/fixit.html>

1/28/98.



Leave Behind Materials For Childcare Centres and Parents

After retrofitting you child's childcare centre, you can continue to protect the children by leaving additional safety tips with the centre's owners and operators. ICLR has made available a piece titled "Being Prepared Before a Disaster Strikes." In this handout, we recommend such commonsense measures as preparing a disaster kit, disposing of paint cans and keeping poison control information on hand.

In addition, this section also includes a series of handouts called "Protecting Your Home". These handouts allow you to take the next step in fostering natural disaster mitigation-protecting the families at home. The guides offer parents techniques they can implement to make their homes more resilient against earthquakes, floods, wildfires, and hailstorms. They also include additional sources for your information. Pick out the hazards which affect your local community and encourage your childcare centre to send the handouts home with the children.

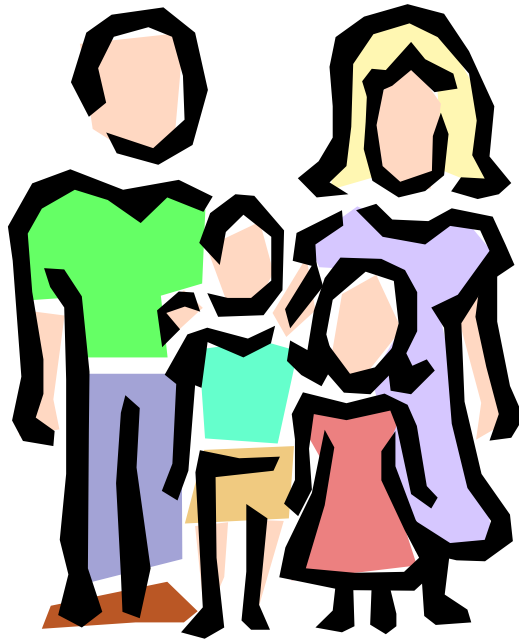

Protecting your Home...

Being Prepared Before a Disaster Strikes

The work that volunteers completed today has made your childcare centre a safer place. But keeping bookcases upright and glass in its frame is just the beginning. Take these extra precautions to protect your charges as fully as possible.

- Make certain your building has smoke detectors on each floor. Check them monthly with a heat source like a lighter or candle. Using a broom can damage the smoke detector.
- If your facility has gas, oil, or wood heat, install a carbon monoxide detector in each separate area.
- Train all of your employees what to do during an emergency. Make certain all staff members know where the extinguisher is located and how to use it.

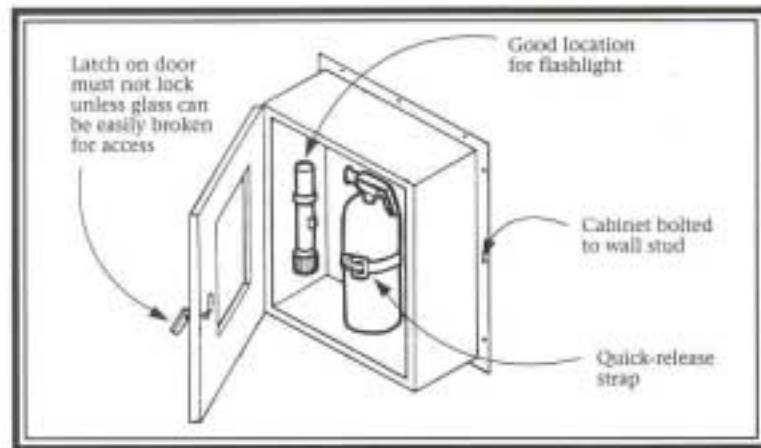

- Know where utility connections are located. Learn how and when to turn them off. However, don't try to turn them back on yourself. Have the fire department or gas and electric companies turn the utilities back on when the area is secure.
- Dispose of paint cans, caustic substances and chemicals, or store them in a safe place away from children. Be sure all of these substances have current and accurate labels. Keep basic information, including poison control information, on hand for each substance.
- Re-inspect your facility on a regular basis to ensure continued adherence to these recommendations.



Protecting your Home...

Against Everyday Disasters

Seemingly innocent items like the teddy bear in the toy box, or a child's winter coat can actually be just as hazardous to your charges as unsecured cabinets or falling light fixtures. Cords on mini-blinds can cause a child to strangle or suffocate. Hard playground surfaces can cause head injuries in a fall. Follow these recommendations to be certain that your childcare setting is as safe as possible every day.

- ✓ **CRIBS:** Make sure cribs are in good condition and meet current national safety standards (look for a certification safety seal). Avoid older cribs, which may not meet current standards.
- ✓ **SOFT BEDDING:** Avoid using pillows, soft bedding or comforters when putting babies to sleep. Put babies down on their backs with a firm, flat mattress.
- ✓ **PLAYGROUNDS:** Look for safe surfacing on outdoor playgrounds: at least 30 cm (12") of wood chips, mulch, sand or pea gravel, or mats made of safety-tested rubber or rubber-like materials.

Check playground surfacing and equipment regularly to make sure they are in good condition.

- ✓ **SAFETY GATES:** Use safety gates to keep children away from potentially dangerous areas, especially stairs.
- ✓ **WINDOW BLIND AND CURTAIN CORDS:** Be sure there are no drawstrings around the hood and neck of children's clothing. Use other types of clothing fasteners, like snaps, zippers or hook and loop fasteners.
- ✓ **RECALLED PRODUCTS:** Check that you have no recalled toys or products. Keep a current list of recalled children's products readily visible.

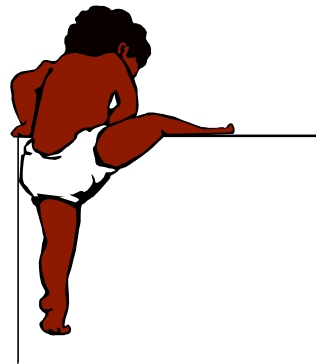

Protecting your Home...

- ✓ Prepare a disaster kit (see Tab 6):

Check your disaster kit two times a year (when the clocks change is a good time) to replace old batteries and change the water and food supplies.

Necessary Tools and Materials

- Smoke detectors _____(quantity)
- Fire extinguishers _____
- Carbon monoxide detectors _____
- Disaster kit materials _____

ATTENTION CHILDCARE CENTRE OWNER/OPERATOR: This information is also important for parents. Please share it with you students' parents so they can make their homes safer as well.

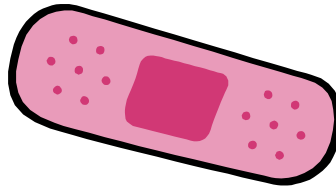

Protecting your Home...

Against Earthquake Damage

Earthquakes can happen anywhere. Fortunately, there are some basic non-structural steps you can take right now to protect your family and your home from disasters. For structural changes, be sure to consult your local building officials and hire a registered design professional, such as an architect, engineer, or licensed building contractor to do the work.

INSIDE YOUR HOUSE:

- Anchor bookcases and filing cabinets to nearby walls.
- Install latches on drawers and cabinet doors to keep contents from spilling.
- Install ledge barriers on shelves, place heavy items on lower shelves, and secure large, heavy items and breakables directly to shelves to keep them from falling.
- Use closed screw eyes and wire to securely attach framed pictures and mirrors to the walls.
- Attach computers and small appliances to desks, tables or countertops.
- Secure ceiling lights, suspended ceilings and other hanging items such as chandeliers and plants to the permanent structure of your house.
- Apply safety film to windows and glass doors.
- Anchor large appliances to walls using safety cables or straps. Lock the rollers of any large appliances or pieces of furniture.
- Secure water heater(s) to nearby walls.
- Fit all gas appliances with flexible connections and/or a breakaway gas shut-off device, or install a main gas shut-off device. (Check your local building codes to determine whether you may install flexible connectors yourself or whether a professional must install them.)

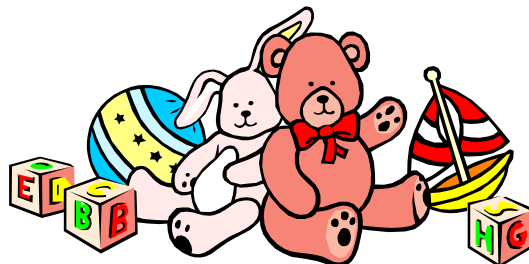

Protecting your Home...

THE HOUSE ITSELF

An earthquake puts your home's structure to the test. It must absorb the earthquake's energy and provide a stable path to transfer these forces back into the ground. Your home is more likely to pass this test when it is properly tied together. That is, when the roof is attached tightly to the walls, the walls are fastened to each other and, finally, when the walls are braced and anchored to a strong foundation.

If the structural elements of your home need reinforcing, some of the most important and common retrofits include:

- Adding anchor bolts or steel plates between your home and its foundation.
- Bracing the inside of your home's cripple wall – the short wood-stud wall between the top of the foundation wall and the first floor – with sheathing.
- Bracing unreinforced chimneys, masonry and concrete walls and foundations.

BEFORE AN EARTHQUAKE STRIKES

You can improve the odds of your home surviving an earthquake by taking these precautions, but you won't make it quake-proof. Nor do these measures guarantee your safety. Earthquakes strike with no warning, so take these additional steps to protect yourself and your family as fully as possible:

- Teach everyone to “duck” or drop to the floor, take “cover” under a desk or table and “hold” on to it when an earthquake strikes. Remember the phrase: “duck, cover, and hold.”
- Become familiar with your community's disaster preparedness plans and create a family plan. Identify escape routes from your home and neighbourhood and designate an emergency meeting place for the family to reunite if you become separated. Practice your family's plan. Also establish a contact point to communicate with concerned relatives.
- Make certain all adult and teenage members of the family know where your gas, electric and water main shutoff controls are and how to turn them off if there is a leak or electrical short. Keep necessary wrenches close by.
- Put together a disaster kit. (See Tab 6)
- Learn First Aid and CPR.



Protecting your Home...

WHEN AN EARTHQUAKE STRIKES

- If you are indoors when an earthquake strikes, stay there. Move away from windows, skylights, doors and things that can fall. “Duck, cover and hold” until the shaking stops. Do not run out of a building - you may be hit by falling debris.
- If you are outdoors, move quickly and safely into the open, away from electrical lines, trees and buildings. Drop to the ground and wait for the shaking to stop.
- If you are driving, carefully and slowly bring your vehicle to a stop at the side of the road away from traffic. Do not stop on or under bridges, under power lines or near roadway signs that might fall. Once the shaking has stopped you can continue driving, but watch carefully for possible damage to the roadway.

AFTER AN EARTHQUAKE STRIKES

- Check for gas or water leaks and electrical shorts, and turn off damaged utilities. However, don't try to turn them back on yourself. Have the fire department or gas and electric companies turn the utilities back on when the area is secured.
- Check for injuries and administer first aid as needed.
- Check your food and water supplies. Do not eat anything from open containers near shattered glass.
- Listen to and follow the advice and recommendations of local aid organizations, including the emergency management office, the fire department and the utility companies.
- Keep roads and phone lines clear for emergency use.
- Obey evacuation orders from local authorities.
- Be prepared for aftershocks.



Protecting your Home...

Against Flood Damage

Rain. Tides. Levee failure. Ice jam. Snow melt. Floods happen, and they happen beside rivers, on the coast, in deserts and on city streets. You don't have to lose your home and possessions to rampaging waters, however. It's never too early to prepare and you can take several basic steps right now to protect your family and your home from disaster.

FIRST THINGS FIRST

Areas near lakes, rivers, or streams can be subject to rising water. Beachfront homes can be susceptible to wind-driven waves as well as rising water.

Whether you live near a river or on the ocean's shore, you should know the expected flooding level in your area. In other words, the base flood elevation (BFE). Consult your local building authority for the base flood elevation in your immediate area.

Also check building department records or your property survey for the elevation of your home's lowest floor. This is the lowest enclosed area in your home, including any area – your basement, for instance – that is below ground level on all sides. If you are unable to determine your house's lowest floor elevation, hire a licensed surveyor to do it.

BEFORE A FLOOD HAPPENS

You can take the following precautions to prevent damage from rising water levels:

- Use water-resistant building materials in areas below the base flood elevation.
- Leave the basement or lower floors unfinished if they're below the base flood elevation.
- Prevent sewer lines from backing up by installing backflow valves or standpipes.
- Raise your washer and dryer and other equipment such as the water heater, oil tanks, furnace and electrical wiring on concrete blocks and above the base flood elevation level. If you are unable to raise a particular item, consider anchoring it and protecting it with a floodwall or shield.
- Install flood shields or built-up barriers for basement windows and doors. The tops of shields and barriers should extend above the base flood elevation.
- Install and maintain a sump pump system if you have below-grade floors.
- Landscape with native plants and vegetation that resist soil erosion.



Protecting your Home...

WHEN A FLOOD THREATENS

You can improve the odds of your home surviving a flood by taking these precautions, but you won't make it flood-proof. Nor do these measures guarantee your safety. Take these additional steps to protect yourself and your family as fully as possible:

- Become familiar with your community's disaster preparedness plans and create a family plan. Identify escape routes from your home and neighbourhood and designate an emergency meeting place for your family to reunite if you become separate. Also establish a contact point to communicate with concerned relatives.
- Put together a disaster kit. (See Tab 6)
- If flooding threatens, follow weather and news reports so you know how much danger you're facing. Obey evacuation orders from local authorities.

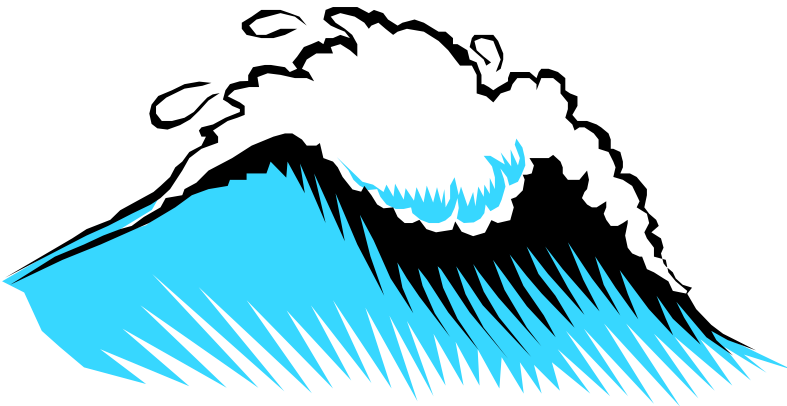

Protecting your Home...

Against Hail Damage

Hail can occur in any strong thunderstorm, which means hail is a threat everywhere. When it hits, it can shred roof coverings and lead to water damage in your ceilings, walls, floors, appliances and personal possessions. Knowing which roof coverings resist impact well can save you lots of trouble and money.

Keep in mind, however, that most roofing jobs are not for the do-it-yourselfer. Unless you have lots of experience in replacing roof coverings, hire a professional roofing contractor to handle this job. And before you reroof, check with your local building officials to be sure what you're doing complies with local building codes.

BEFORE A HAILSTORM STRIKES

- Cover windows with window film because large hailstones can cause them to shatter.
- When you replace your roof covering, make sure you use asphalt shingles that did not crack when hit twice in the same area. In the US this is a class 4 rating. Some roof coverings, particularly some made of metal, may resist cracking but can be dented and dimple. So, while these roof covering may test well, they may perform poorly in practice. Keep this in mind when gauging the quality of a roof covering.

WHEN A HAILSTORM STRIKES

- If you are indoors when a storm with large hailstones strikes, stay there. Because large pieces of hail can shatter windows, close your drapes, blinds or window shades to prevent the wind from blowing broken glass inside. Stay away from skylights and doors.
- If you are outside, move immediately to a place of shelter.

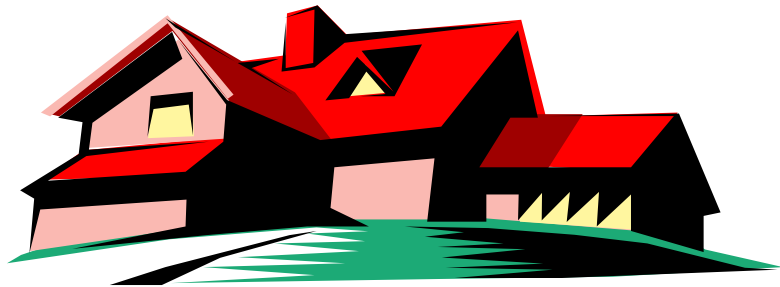

Protecting your Home...

Against Damage From Freezing Weather

With the arrival of winter comes the potential for ruined carpets and water damage to your ceilings and walls caused by ice dams or bursting pipes. Fortunately, there are some basic non-structural steps you can take to help prevent this kind of damage to your home. For structural changes, be sure to consult your local building officials, and hire a registered design professional, such as an architect, engineer or licensed building contractor to do the work.

ICE DAMS

An ice dam is an accumulation of ice at the lower edge of a sloped roof, usually at the gutter. When interior heat melts the snow on the roof, the water runs down and refreezes at the roof's edge, where temperatures are much cooler. Eventually, the ice builds up and blocks water from draining off the roof. This, in turn, forces the water under the roof covering and into your attic or down the inside walls of your house.

Once an ice dam forms the potential damage can be serious. Take these steps now to avoid trouble later:

- Keep the attic well ventilated. The colder the attic, the less melting and refreezing on the roof.
- Keep the attic floor well insulated to minimize the amount of heat rising through the attic from within the house.

This two-step approach decreases the likelihood that ice dams will form or, at least, reduces their size.

As an extra precaution against roof leaks (in case ice dams do form), install a water-repellent membrane under your roof covering. Talk with your local building official about minimum code requirements for ice dam protection.

Unfortunately, ice dams may be unavoidable if your home has recessed lighting near the roof. Heat generated from these lights melts the snow, which then contributes to ice dam buildup. The only sure way to avoid this problem is to eliminate recessed light fixtures near the roof.



Protecting your Home...

FREEZING PIPES

Frozen water in pipes can cause water pressure buildup between the ice blockage and the closed faucet at the end of the pipe. This leads to pipes bursting at their weakest point. Pipes in attics, crawl spaces and outside walls are particularly vulnerable to freezing in extremely cold weather, where outside holes for television, cable or telephone lines allow cold air to reach them.

To keep water in pipes from freezing, take the following steps:

- Fit exposed pipes with insulation sleeves or wrapping to slow the heat transfer. The more insulation, the better.
- Seal cracks and holes in outside walls and foundations near water pipes with caulking.
- Keep cabinet doors open during cold spells to allow warm air to circulate around pipes (particularly in the kitchen and bathroom).
- Keep a slow trickle of water flowing through faucets connected to pipes that run through an unheated or unprotected space. Or drain the water system, especially if your house will be unattended during cold periods.



Protecting your Home...

Against Hurricane Damage

Hurricanes are like no other storms on earth. Although Canada is not affected by them on a regular basis, we do get hurricane-force winds and torrential rain.

Find out if your home meets current model building code requirements for high-wind regions. Experts agree that structures built to meet or exceed current model building codes' high-wind provisions have a much better chance of surviving violent windstorms.

If you're handy with a hammer and saw, you can do much of the work yourself. Work involving your home's structure may require a building contractor, however, or even a registered design professional such as an architect or engineer.

WHEN WORKING OUTSIDE

- Replace gravel-rock landscaping material with shredded bark.
- Keep trees and shrubbery trimmed. Cut weak branches and trees that could fall on your house.

WHEN BUILDING OR REMODELING

- **Entry Doors:** Make certain your doors have at least three hinges and a dead bolt security lock with a bolt at least one inch long. Anchor door frames securely to wall framing. If you have double doors, secure them with head and foot bolts.
- **Windows:** Cover your windows with protective film to prevent the glass from shattering if they are broken.
- **Garage Doors:** Because of their size, garage doors are highly susceptible to wind damage. A qualified inspector can determine if both the door and the track system can resist high winds and, if necessary, replace them with a strong system.

Garage doors more than eight feet wide are most vulnerable. Install permanent wood or metal stiffeners. Or contact the door manufacturer's technical staff for recommendations about temporary centre supports that you can attach and remove easily when severe weather threatens.



Protecting your Home...

- **Roofs:** If you are replacing your roof, take steps to ensure that both the new roof covering and the sheathing it attaches to will resist high winds. Your roofing contractor should:
 - Remove old coverings down to the bare wood sheathing.
 - Remove enough sheathing to confirm that rafters and trusses are securely connected to the walls.
 - Replace damaged sheathing.
 - Refasten existing sheathing according to the proper fastening schedule outlined in the current model building code for high-wind regions.
 - Install a roof covering that is designed to resist high winds. Also consider using a double-layer application of heavier felt roofing paper, secured with sufficient tin tabs, to avoid water damage.
 - Seal all roof-sheathing joints with self-stick rubberized asphalt tape to provide a secondary moisture barrier.

If you want to give your roof sheathing added protection, but it's not time to re-roof, glue the sheathing to the rafters and trusses. Use an adhesive that conforms to Performance Specification AFG-01 developed by APA – the Engineered Wood Association, which you can find at any hardware store or home improvement centre.

- **Gables:** Make certain the end wall of a gable roof is braced properly to resist high winds. Check the current model building code for high-wind regions for appropriate guidance, or consult a qualified architect or engineer.
- **Connections:** The points where the roof and the foundation meet the walls of your house are extremely important if your house is to resist high winds and the pressures they place on the entire structure.
 - Anchor the roof to the walls with metal clips and straps (most easily added when you replace your roof).
 - Make certain the walls are properly anchored to the foundation. A registered design professional can determine if these joints need retrofitting, and a qualified contractor can perform the work the design professional identifies.
 - If your house has more than one story, make certain the upper story wall framing is firmly connected to the lower framing. The best time to do this is when you remodel.



Protecting your Home...

WHEN A HURRICANE THREATENS

You can improve the odds of your home surviving high winds by taking these precautions, but you won't make it hurricane-proof. Nor do these measures guarantee your safety. Take these additional steps to protect yourself and your family as fully as possible:

- Become familiar with your community's disaster preparedness plans and create a family plan. Identify escape routes from your home and neighbourhood and designate an emergency meeting place for your family to reunite if you become separated. Also establish a contact point to communicate with concerned relatives.
- Put together an emergency kit that includes a three-day supply of drinking water and food you don't have to refrigerate or cook; first aid supplies; a portable AM/FM radio; a wrench and other basic tools; a flashlight; work gloves; emergency cooking equipment; portable lanterns; fresh batteries for each piece of equipment; clothing; blankets; baby items; prescription medications; extra car and house keys; extra eyeglasses; credit cards and cash; important documents, including insurance policies.
- Move anything that can become flying debris from your yard into your house or garage before a storm strikes.
- If a hurricane threatens, follow weather and news reports so you know how much danger you're facing. Obey evacuation orders from local authorities.



Protecting your Home...

Against Tornado Damage

While no house can withstand a direct hit from a severe tornado, structures built to meet or exceed current model building codes for high-wind regions have a much better chance of surviving when a tornado passes nearby.

WHEN WORKING OUTSIDE

- Replace gravel-rock landscaping material with shredded bark.
- Keep trees and shrubbery trimmed. Cut weak branches and trees that could fall on your house.

WHEN BUILDING OR REMODELING

- **Entry Doors:** Make certain your doors have at least three hinges and a dead bolt security lock with a bolt at least one inch long. Anchor door frames securely to wall framing. If you have double doors, secure them with head and foot bolts.
- **Windows:** Cover your windows with protective film to prevent the glass from shattering if they are broken.
- **Garage Doors:** Because of their size, garage doors are highly susceptible to wind damage. A qualified inspector can determine if both the door and the track system can resist high winds and, if necessary, replace them with a strong system.

Garage doors more than eight feet wide are most vulnerable. Install permanent wood or metal stiffeners. Or contact the door manufacturer's technical staff for recommendations about temporary centre supports that you can attach and remove easily when severe weather threatens.



Protecting your Home...

- **Roofs:** If you are replacing your roof, take steps to ensure that both the new roof covering and the sheathing it attaches to will resist high winds. Your roofing contractor should:
 - Remove old coverings down to the bare wood sheathing.
 - Remove enough sheathing to confirm that rafters and trusses are securely connected to the walls.
 - Replace damaged sheathing.
 - Refasten existing sheathing according to the proper fastening schedule outlined in the current model building code for high-wind regions.
 - Install a roof covering that is designed to resist high winds. Also consider using a double-layer application of heavier felt roofing paper, secured with sufficient tin tabs, to avoid water damage.
 - Seal all roof-sheathing joints with self-stick rubberized asphalt tape to provide a secondary moisture barrier.

If you want to give your roof sheathing added protection, but it's not time to re-roof, glue the sheathing to the rafters and trusses. Use an adhesive that conforms to Performance Specification AFG-01 developed by APA – the Engineered Wood Association, which you can find at any hardware store or home improvement centre.

- **Gables:** Make certain the end wall of a gable roof is braced properly to resist high winds. Check the current model building code for high-wind regions for appropriate guidance, or consult a qualified architect or engineer.
- **Connections:** The points where the roof and the foundation meet the walls of your house are extremely important if your house is to resist high winds and the pressures they place on the entire structure.
 - Anchor the roof to the walls with metal clips and straps (most easily added when you replace your roof).
 - Make certain the walls are properly anchored to the foundation. A registered design professional can determine if these joints need retrofitting, and a qualified contractor can perform the work the design professional identifies.
 - If your house has more than one story, make certain the upper story wall framing is firmly connected to the lower framing. The best time to do this is when you remodel.



Protecting your Home...

WHEN A TORNADO THREATENS

You can improve the odds of your home surviving high winds by taking these precautions, but you won't make it tornado-proof. Nor do these measures guarantee your safety. Take these additional steps to protect yourself and your family as fully as possible:

- Decide in advance where you will take shelter (a local community shelter, perhaps, or your own underground storm cellar or in-residence "safe" room). When a tornado approaches, go there immediately. If your home has no storm cellar or in-residence "safe" room and you have no time to get to a community shelter, head to the centermost part of your basement or home – away from windows and preferably under something sturdy like a workbench or staircase. The more walls between you and the outside, the better. If your building has no basement go to an interior hall. A smaller room is usually better than a large room.
- Become familiar with your community's severe weather warning system and make certain every adult and teenager in your family knows what to do when a tornado "watch" or "warning" sounds. Learn about you workplace's disaster safety plans and similar measures at you children's school or childcare centre.
- Study your community's disaster preparedness plans and create a family plan in case you are able to move to a community shelter. Identify escape routes from your home and neighbourhood and designate an emergency meeting place for the family to reunite if you become separated. Also establish a contact point to communicate with concerned relatives.
- Put together a disaster kit. (See Tab 6)
- Move anything that can become flying debris from your yard inside your house or garage before a storm strikes. Do this only if authorities have announced a tornado "watch", however. If authorities have announced a tornado "warning", leave it all alone.
- Don't open your windows. You won't save the house, as once thought, you may actually make thing worse by giving wind and rain a chance to get inside.
- Don't try to ride out a tornado in a manufactured home. Even manufactured homes with tie-downs overturn in these storms because they have light frames and offer the wind a large surface area to push against. In addition, their exteriors are vulnerable to high winds and wind-borne debris.



Protecting your Home...

Against Fire Damage

You are vulnerable to fires during hot and dry seasons even though you may live in a thoroughly contemporary suburb. Completing some of the following non-structural steps will improve your home's resistance to fires of any kind.

WHEN WORKING OUTSIDE:

Create a zone around your house that will slow the fire down and possibly direct it around your home. To do this, you must view your yard as a fuel source. Fire will only burn if fuel is present. Fuel can include your landscaping, woodpiles, decks, etc. To create your survivable space, take the following steps within 9 m (30') of your home, 15 m (50') if you live in a heavily treed area or 30.5 m (100') if your home is on a hillside.

- Make sure the street number of your house is clearly visible and legible from the road
- Create a “defensible space” by removing all dry grass, brush, trees and dead leaves within at least 30.5 m (100') from your home.
- Plant native, fire-resistive vegetation whenever possible.
- Space trees and shrubs at least 3 m (10') apart. Reduce the number of trees in heavily wooded areas.
- For trees taller than 5.5 m (18'), prune lower branches within six feet of the ground to keep ground fires from spreading in to treetops.
- Remove all dead branches overhanging your roof and all branches within 3 m (10') of chimneys.
- Enclose the underside of balconies and aboveground decks with fire-resistive or noncombustible materials.
- Cover chimneys serving fireplaces with noncombustible screening with a mesh size no greater than 0.5 cm (1/4”).
- Store firewood at least 15.25 m (50') from any structure.
- Clearly mark all emergency water sources and maintain easy access.
- Maintain an emergency water supply within 300 m (1,000') of your home. Check with your local fire department to learn what standards you must meet.
- Mow your lawn regularly and dispose promptly of cuttings and debris.
- Clear your roof, gutters and eaves of debris.
- Do not connect wooden fencing directly to your home.



Protecting your Home...

WHEN BUILDING OR REMODELING

- Cover attic and sub-floor vents with noncombustible screening with a mesh size no greater than 0.5 cm (¼”).
- Your roof is the most vulnerable part of your home because it can easily catch fire from wind-blown sparks. If you are building a new home or reroofing your existing house, use roof covering material with a Class A fire-resistive rating.
- Limit the size and number of windows that face large areas of vegetation. The heat from a wildfire can ignite the furnishings inside your home through these windows.
- Install tempered glass or multi-layered glazed panels in exterior walls, glass doors and sky-lights. Or install solid, exterior shutters.

WHEN A WILDFIRE THREATENS

You can improve the odds of your home surviving a wildfire by taking these precautions, but you won't make it fireproof. Nor do these measures guarantee your safety. Take these additional steps to protect yourself and your family as fully as possible:

- Become familiar with your community's disaster preparedness plans and create a family plan. Identify escape routes from your home and neighbourhood and designate an emergency meeting place for the family to reunite if you become separated. Also establish a contact point to communicate with concerned relatives.
- Put together a disaster kit. (See Tab 6)
- If a wildfire threatens, follow news reports so you know how much danger you're facing. Obey evacuation orders from local authorities.



Protecting your Home...

With Insurance

Natural catastrophes can strike with little or no warning. So can man-made disasters. You can improve the odds of your home surviving an earthquake or an accidental fire by taking certain precautions, but you won't make it disaster-proof. To protect the investment you've made in your home as fully as possible, review your home owners insurance policy periodically with your insurance agent or company. Make certain you have all the necessary protection for the threats you face. And check the dollar limits to be sure you have enough coverage to rebuild your home and your life should misfortune occur.

AFTER DISASTER STRIKES

If your home is damaged in either a natural disaster or a man-made one, report it immediately to your insurance agent or company representative and make temporary repairs to prevent further damage.



Protecting your Home...